

Tubes SDW und SMW

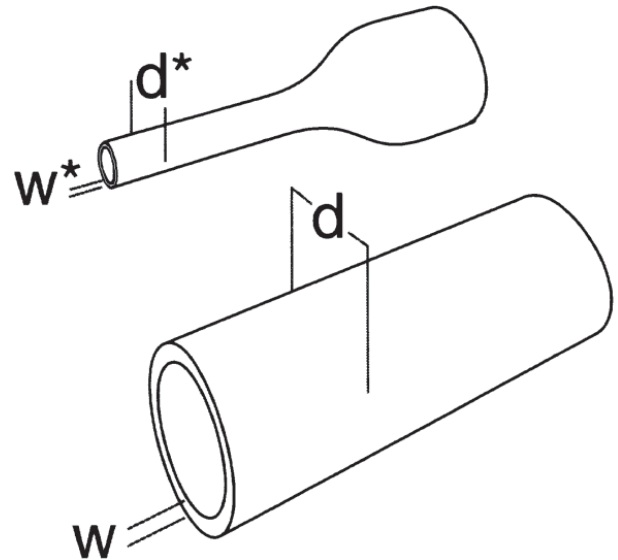

Thick Wall Tubes
Medium Wall Tubes
 heat shrink technique



Application

Thick wall and medium wall heat shrink tubes for electrical insulation, for sealing and as corrosion protection – with or without adhesives.

Shrink Tubes		Dimensions (mm) *after free contraction			
with adhesive	without adhesive	d inner	d* inner	w*	Lenght
Thick Wall Tubes					
SDW 12/3	SDW 12-3-U	12	3	2,6	1000
SDW 16/4	SDW 16/4-U	16	4	3,1	1000
SDW 22/6	SDW 22/6-U	22	6	2,7	1000
SDW 33/8	SDW 33/8-U	33	8	4,0	1000
SDW 45/12	SDW 45/12-U	45	12	4,4	1000
SDW 55/15	SDW 55/15-U	55	15	4,4	1000
SDW 75/20	SDW 75/20-U	75	20	4,5	1000
SDW 92/25	SDW 92/25-U	92	25	4,6	1000
SDW 130/34	SDW 130/34-U	130	34	4,8	1000
Medium Wall Tubes					
SMW 8/2	SMW 8/2-U	8	2	1,7	1000
SMW 12/3	SMW 12/3-U	12	3	2,1	1000
SMW 22/6	SMW 22/6-U	22	6	2,6	1000
SMW 34/7	SMW 34/7-U	34	7	2,6	1000
SMW 40/12	SMW 40/12-U	40	12	2,6	1000
SMW 56/16	SMW 56/16-U	56	16	2,7	1000
SMW 75/22	SMW 75/22-U	75	22	3,0	1000
SMW 95/26	SMW 95/26-U	95	26	3,2	1000
SMW 120/34	SMW 120/34-U	120	34	3,3	1000
SMW 140/42	SMW 140/42-U	140	42	3,5	1000
SMW 160/50	SMW 160/50-U	160	50	3,5	1000
SMW 175/65	SMW 175/65-U	175	65	3,5	1000