

# 1 kV Straight Joints svm

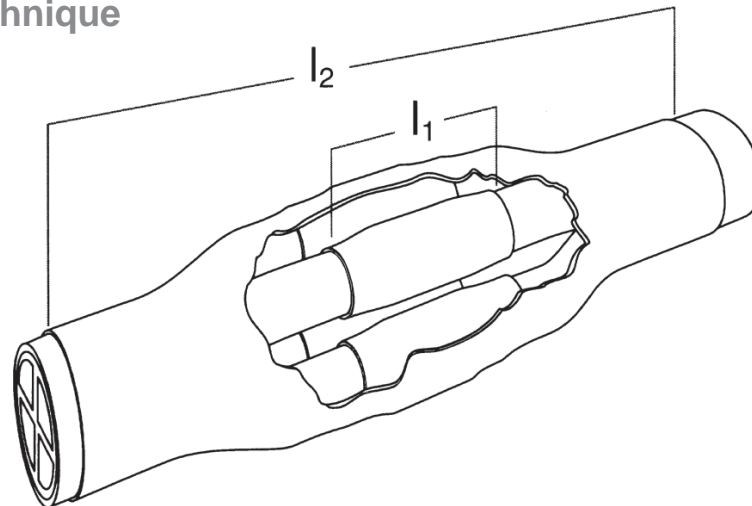

for plastic insulated cables

heat shrink technique



| Cable<br>Cross Section                    | Joint<br>Type            | Dimensions (mm)        |                        |
|-------------------------------------------|--------------------------|------------------------|------------------------|
|                                           |                          | l <sub>1</sub> (inner) | l <sub>2</sub> (outer) |
| 4-core plastic cable                      |                          |                        |                        |
| 1,5 – 16 mm <sup>2</sup>                  | <b>SVM 1,5-16 / 4</b>    | 100                    | 400                    |
| 16 – 50 mm <sup>2</sup>                   | <b>SVM 16-50 / 4</b>     | 150                    | 600                    |
| 25 – 95 mm <sup>2</sup>                   | <b>SVM 25-95 / 4</b>     | 200                    | 600                    |
| 25 – 150 mm <sup>2</sup>                  | <b>SVM 25-150 / 4</b>    | 250                    | 700                    |
| 95 – 300 mm <sup>2</sup>                  | <b>SVM 95-300 / 4</b>    | 300                    | 1000                   |
| 4-core plastic cable for screw connectors |                          |                        |                        |
| 6 – 35 mm <sup>2</sup>                    | <b>SMV 6-35 / 4-SV</b>   | 120                    | 400                    |
| 25 – 70 mm <sup>2</sup>                   | <b>SMV 25-70 / 4-SV</b>  | 150                    | 550                    |
| 70 – 150 mm <sup>2</sup>                  | <b>SMV 70-150 / 4-SV</b> | 230                    | 700                    |
| 5-core plastic cable                      |                          |                        |                        |
| 1,5 – 6 mm <sup>2</sup>                   | <b>SVM 1,5-6 / 5</b>     | 50                     | 250                    |
| 1,5 – 16 mm <sup>2</sup>                  | <b>SVM 1,5-16 / 5</b>    | 100                    | 400                    |

## Cables

e.g. N(A)YY, N(A)2X2Y, N(A)YCWY etc.  
with PVC or PE/XLPE insulation.

## Specification

- inner-tubes
- outer-tube
- installation instructions

# 1 kV Transition Joints sÜM



heat shrink technique

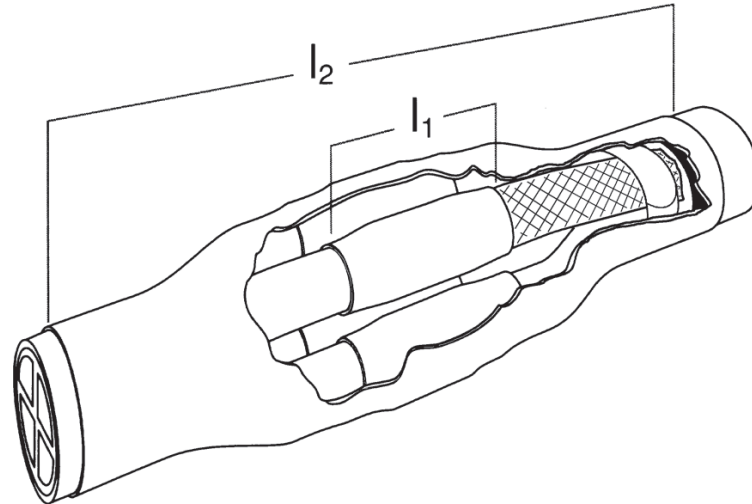

| Cable<br>Cross Section    | Joint<br>Type | Measurements (mm)      |                        |
|---------------------------|---------------|------------------------|------------------------|
|                           |               | l <sub>1</sub> (inner) | l <sub>2</sub> (outer) |
| 25 – 70 mm <sup>2</sup>   | SÜM 25-70     | 200                    | 800                    |
| 70 – 150 mm <sup>2</sup>  | SÜM 70-150    | 250                    | 1000                   |
| 150 – 300 mm <sup>2</sup> | SÜM 150-300   | 300                    | 1200                   |

## Cables

Joining of paper insulated cables N(A)KBA  
to polymeric cables e.g. N(A)YY, N(A)2X2Y, N(A)YCWY

## Specification

- inner-tubes
- outer-tubes
- core-tubes
- spreader cap
- earthing braid
- roll spring
- assembly material
- installation instructions

# 1 kV Voltage Proof End Caps SEM



heat shrink technique

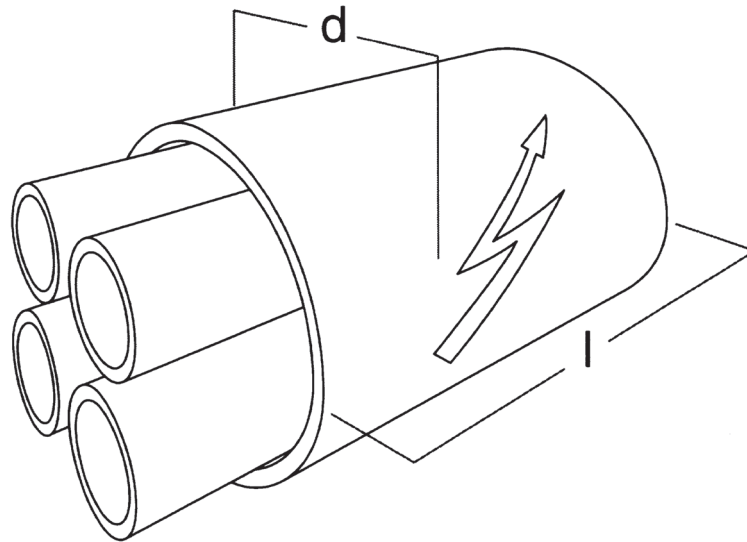

| Cable<br>Cross Section | Joint<br>Type   | Dimensions (mm) |         |
|------------------------|-----------------|-----------------|---------|
|                        |                 | l               | d       |
| 6 – 25                 | SEM 6-25/4-K    | ca. 100         | 15 – 35 |
| 35 – 150               | SEM 35-150/4-K  | ca. 150         | 25 – 55 |
| 185 – 300              | SEM 185-300/4-K | ca. 160         | 30 – 75 |

## Cables

e.g. N(A)YY, N(A)2X2Y, N(A)YCWY  
with PVC or PE/XLPE insulation.

## Specification

- 4 inner-caps
- outer-cap with voltage sign
- installation instructions

# End Caps SEK



heat shrink technique

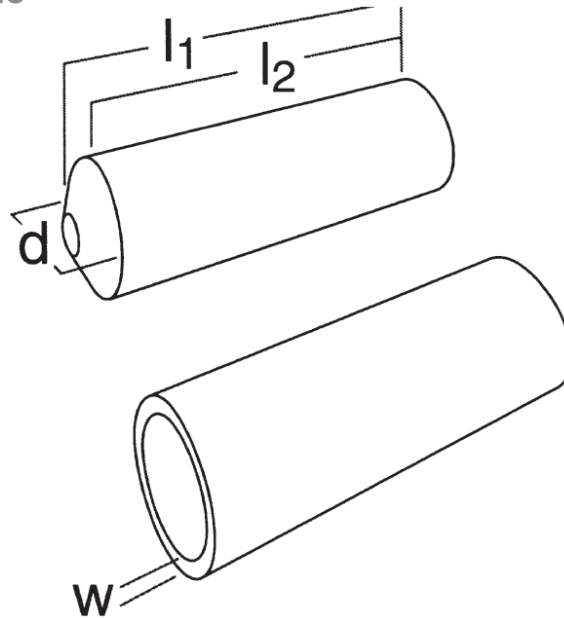

| End Cap    | Dimensions (mm) |           |          |           |     |
|------------|-----------------|-----------|----------|-----------|-----|
|            | d<br>max        | d*<br>min | l<br>max | l*<br>min | w*  |
| SEK 15-5   | 15              | 5         | 45       | 45        | 2,0 |
| SEK 22-9   | 22              | 9         | 75       | 70        | 2,5 |
| SEK 35-15  | 35              | 15        | 100      | 95        | 3,0 |
| SEK 55-25  | 55              | 25        | 150      | 140       | 3,5 |
| SEK 75-30  | 75              | 30        | 180      | 155       | 3,5 |
| SEK 95-40  | 95              | 40        | 175      | 155       | 4,0 |
| SEK 110-45 | 110             | 45        | 145      | 130       | 4,0 |

\* Dimension after free contraction

## Application

End caps are an economic solution to seal energy and control cable ends. They are resistant to chemicals, UV-rays and are non-aging.

# Spreader Caps SAK



heat shrink technique

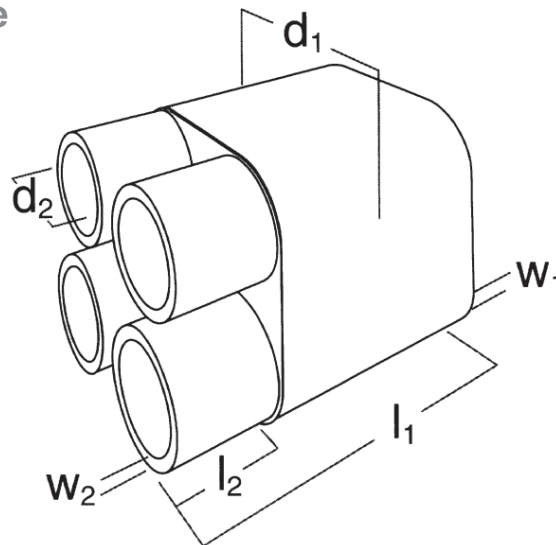

| 3-Finger-Cap | Dimensions (mm)    |                      |                    |                      |                     |                       |         | Cross Section (mm <sup>2</sup> ) |
|--------------|--------------------|----------------------|--------------------|----------------------|---------------------|-----------------------|---------|----------------------------------|
|              | d <sub>1</sub> max | d <sub>1</sub> * min | d <sub>2</sub> max | d <sub>2</sub> * min | l <sub>1</sub> -10% | l <sub>1</sub> * -10% | w* -10% |                                  |
| SAK 35-15/3  | 35                 | 15                   | 12                 | 2,5                  | 85                  | 125                   | 3,0     | 6 – 35                           |
| SAK 55-23/3  | 55                 | 23                   | 30                 | 9                    | 115                 | 180                   | 3,0     | 25 – 150                         |
| SAK 75-30/3  | 75                 | 30                   | 29                 | 8                    | 170                 | 215                   | 3,5     | 95 – 240                         |
| SAK 110-35/3 | 110                | 35                   | 40                 | 17,5                 | 145                 | 230                   | 4,0     | 150 – 300                        |

| 4-Finger-Cap | Dimensions (mm)    |                      |                    |                      |                     |                       |         | Cross Section (mm <sup>2</sup> ) |
|--------------|--------------------|----------------------|--------------------|----------------------|---------------------|-----------------------|---------|----------------------------------|
|              | d <sub>1</sub> max | d <sub>1</sub> * min | d <sub>2</sub> max | d <sub>2</sub> * min | l <sub>1</sub> -10% | l <sub>1</sub> * -10% | w* -10% |                                  |
| SAK 35-15/4  | 35                 | 15                   | 13,5               | 3,0                  | 85                  | 110                   | 3,8     | 4 – 25                           |
| SAK 47-23/4  | 47                 | 23                   | 21,5               | 6,4                  | 110                 | 165                   | 4,1     | 35 – 95                          |
| SAK 60-23/4  | 60                 | 23                   | 30                 | 6,4                  | 130                 | 170                   | 4,1     | 25 – 150                         |
| SAK 78-36/4  | 78                 | 36                   | 38                 | 12,5                 | 150                 | 240                   | 4,0     | 95 – 240                         |
| SAK 95-36/4  | 95                 | 36                   | 40                 | 12,5                 | 140                 | 240                   | 4,0     | 120 – 300                        |

\* Dimension after free contraction

## Application

Spreader caps are an economic solution to seal energy and control cable ends. They are resistant to chemicals, UV-rays and are non-aging.

## Notice

When using on paper insulated cables put a medium-wall shrink tube on the paper insulation first.

The diameter of the spreader cap has to be 5 mm larger than the cable diameter.

# Tubes SDW und SMW



**Thick Wall Tubes**  
**Medium Wall Tubes**  
 heat shrink technique

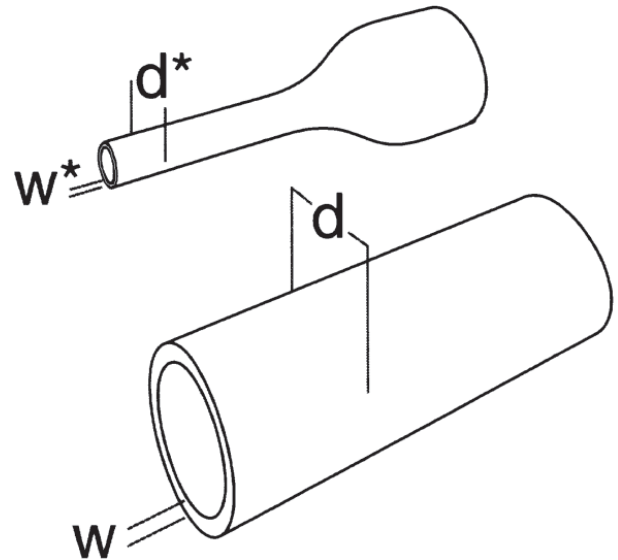

## Application

Thick wall and medium wall heat shrink tubes for electrical insulation, for sealing and as corrosion protection – with or without adhesives.

| Shrink Tubes             |                  | Dimensions (mm)<br>*after free contraction |          |     |        |
|--------------------------|------------------|--------------------------------------------|----------|-----|--------|
| with adhesive            | without adhesive | d inner                                    | d* inner | w*  | Lenght |
| <b>Thick Wall Tubes</b>  |                  |                                            |          |     |        |
| SDW 12/3                 | SDW 12-3-U       | 12                                         | 3        | 2,6 | 1000   |
| SDW 16/4                 | SDW 16/4-U       | 16                                         | 4        | 3,1 | 1000   |
| SDW 22/6                 | SDW 22/6-U       | 22                                         | 6        | 2,7 | 1000   |
| SDW 33/8                 | SDW 33/8-U       | 33                                         | 8        | 4,0 | 1000   |
| SDW 45/12                | SDW 45/12-U      | 45                                         | 12       | 4,4 | 1000   |
| SDW 55/15                | SDW 55/15-U      | 55                                         | 15       | 4,4 | 1000   |
| SDW 75/20                | SDW 75/20-U      | 75                                         | 20       | 4,5 | 1000   |
| SDW 92/25                | SDW 92/25-U      | 92                                         | 25       | 4,6 | 1000   |
| SDW 130/34               | SDW 130/34-U     | 130                                        | 34       | 4,8 | 1000   |
| <b>Medium Wall Tubes</b> |                  |                                            |          |     |        |
| SMW 8/2                  | SMW 8/2-U        | 8                                          | 2        | 1,7 | 1000   |
| SMW 12/3                 | SMW 12/3-U       | 12                                         | 3        | 2,1 | 1000   |
| SMW 22/6                 | SMW 22/6-U       | 22                                         | 6        | 2,6 | 1000   |
| SMW 34/7                 | SMW 34/7-U       | 34                                         | 7        | 2,6 | 1000   |
| SMW 40/12                | SMW 40/12-U      | 40                                         | 12       | 2,6 | 1000   |
| SMW 56/16                | SMW 56/16-U      | 56                                         | 16       | 2,7 | 1000   |
| SMW 75/22                | SMW 75/22-U      | 75                                         | 22       | 3,0 | 1000   |
| SMW 95/26                | SMW 95/26-U      | 95                                         | 26       | 3,2 | 1000   |
| SMW 120/34               | SMW 120/34-U     | 120                                        | 34       | 3,3 | 1000   |
| SMW 140/42               | SMW 140/42-U     | 140                                        | 42       | 3,5 | 1000   |
| SMW 160/50               | SMW 160/50-U     | 160                                        | 50       | 3,5 | 1000   |
| SMW 175/65               | SMW 175/65-U     | 175                                        | 65       | 3,5 | 1000   |

# Repair Sleeves SRM



heat shrink technique

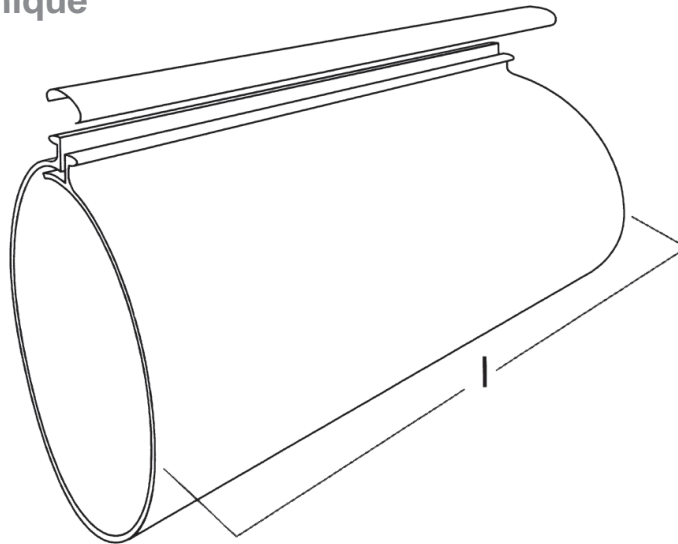

| Repair Sleeve    | Range of Application Ø (mm) | Wall Thickness W (mm)<br>- after free contraction - | Available Lengths l (mm) |
|------------------|-----------------------------|-----------------------------------------------------|--------------------------|
| SRM 28/10 - 750  | 28 – 10                     | 2,3                                                 | 750 *                    |
| SRM 43/12 - 750  | 43 – 12                     | 3,4                                                 | 750 *                    |
| SRM 72/18 - 750  | 72 – 18                     | 3,4                                                 | 750 *                    |
| SRM 93/26 - 750  | 93 – 26                     | 3,4                                                 | 750 *                    |
| SRM 115/30 - 750 | 115 – 30                    | 2,3                                                 | 750 *                    |
| SRM 125/32 - 750 | 125 – 32                    | 2,3                                                 | 750 *                    |

\* other lengths on request

## Application

Repair sleeves are used for a fast and durable repair of damaged cable sheaths. They guarantee a watertight and insulation restoring repair.

# Wall Ducts SMD



heat shrink technique

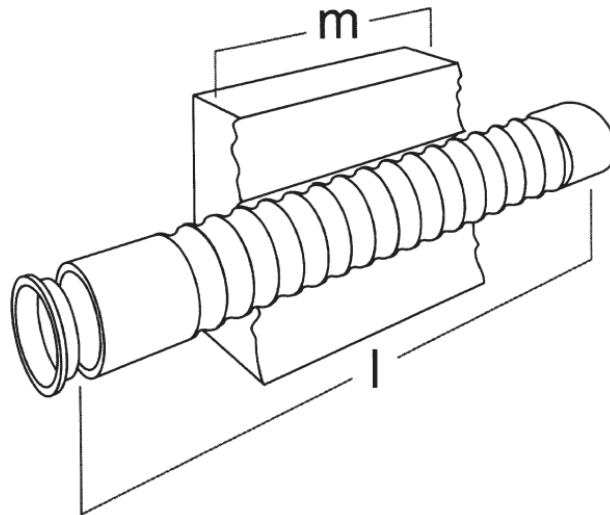

| Wall Duct        | Dimensions (mm)                          |                        |          |
|------------------|------------------------------------------|------------------------|----------|
|                  | Range of Application<br>(cable diameter) | Wall Thickness max. m* | Lenght l |
| <b>SMD 14/8</b>  | 8 – 14                                   | 500                    | 800      |
| <b>SMD 26/12</b> | 12 – 26                                  | 500                    | 800      |
| <b>SMD 41/16</b> | 16 – 41                                  | 500                    | 800      |
| <b>SMD 54/26</b> | 26 – 54                                  | 500                    | 800      |

\* In case of walls > 500 mm you have to connect two wall ducts.

## Application

Wall ducts are used to seal energy and control cables where they pass through a brick or concrete wall.