

# End Caps SEK

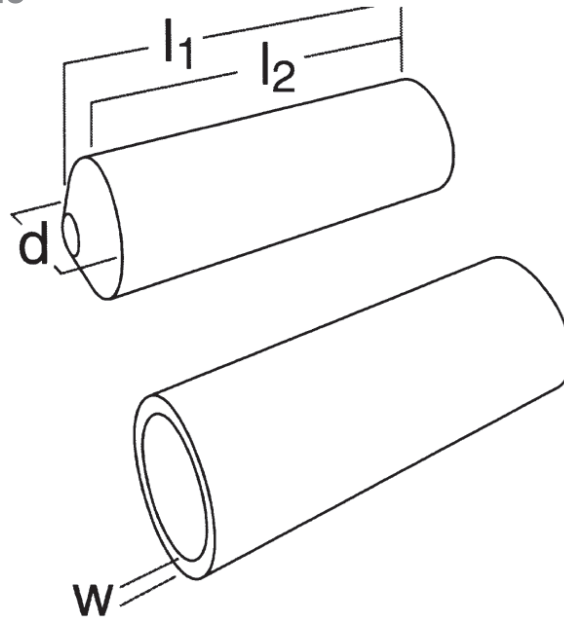

heat shrink technique



End Cap	Dimensions (mm)				
	d max	d* min	l max	l* min	w*
SEK 15-5	15	5	45	45	2,0
SEK 22-9	22	9	75	70	2,5
SEK 35-15	35	15	100	95	3,0
SEK 55-25	55	25	150	140	3,5
SEK 75-30	75	30	180	155	3,5
SEK 95-40	95	40	175	155	4,0
SEK 110-45	110	45	145	130	4,0

\* Dimension after free contraction

## Application

End caps are an economic solution to seal energy and control cable ends. They are resistant to chemicals, UV-rays and are non-aging.