

1 kV Branch and Straight Joint HSM

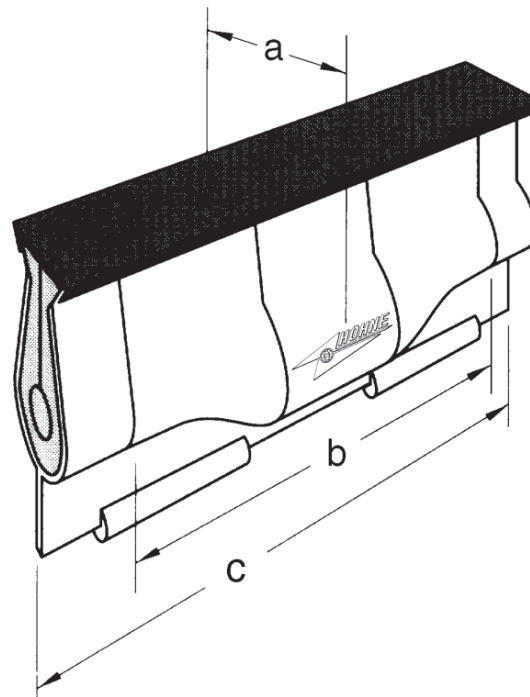

resin technique

HSM 175/40



Main Cable according to DIN/TGL			Branch Cable according to DIN/TGL		
Type	Cross Section (mm ²)	max. Diameter	Type	Cross Section (mm ²)	max. Diameter
N(A)YY, N(A)Y2Y, NA2XY, NA2X2Y	3-5 x 1,5 - 3-5 x 6	17 mm	N(A)YY, N(A)Y2Y, NA2XY, NA2X2Y	3-5 x 1,5 - 3-5 x 4	12 mm

Joint Box Type	Dimensions (mm)			Joint Box Volume	Resin Net Weight	Gross Weight (packed set)
	a= Ø	b	c			
HSM 175/40	40	140	175	165 cm ³	0,225 kg	0,56 kg

Handling

By few and simple mounting steps a fast and operator-safe assembly of the joint box is ensured.

Application

The joint box is suitable for use with single clamps.

Quality

The joint box is system-tested according to VDE 0278 part of 1 and 3 respectively hp 623. Our cast resins fulfill the requirements of VDE 0291 part of 2 respectively hp 631.1.

By application of the quality management system in accordance with DIN EN ISO 9001:2000 the quality of our products is guaranteed.

Specification

- two-part, transparent shell
- PUR and hardener in tins or alternatively in double-chamber bags
- sealings
- stirring spatula (for tins)
- emery cloth
- protection gloves
- installation instructions