

1 kV Branch Joint HSM

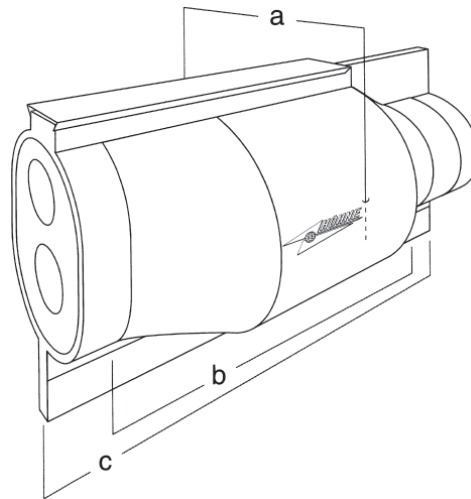

resin technique

HSM 500/180



Main Cable according to DIN/TGL			Branch Cable according to DIN/TGL		
Type	Cross Section (mm ²)	max. Diameter	Type	Cross Section (mm ²)	max. Diameter
N(A)YY, NAY2Y, NA2XY, NA2X2Y	4 x 95 to 4 x 300	65 mm	N(A)YY, NAY2Y, NA2XY, NA2X2Y	4 x 35 to 4 x 185	54 mm
NAYCWY	3 x 95/95 to 3 x 300/185			NAYCWY	
NAKBA	4 x 95 to 4 x 240				
NAKLEY	3 x 95 bis 3 x 185				

Installation of paper-insulated cables is also possible by the use of earthing sets. Please refer to section 8 "cable connectors".

Joint Box Type	Dimensions (mm)			Joint Box Volume	Resin Net Weight	Gross Weight (packed set)
	a= Ø	b	c			
HSM 500/180	180	440	500	8300 cm ³	9,1 kg	11,8 kg

Handling

By few and simple mounting steps a fast and operator-safe assembly of the joint box is ensured.

Application

The joint box is suitable for use with all available cable ring connectors and single clamps.

Quality

The joint box is system-tested according to VDE 0278 part of 1 and 3 respectively hp 623. Our cast resins fulfill the requirements of VDE 0291 part of 2 respectively hp 631.1.

By application of the quality management system in accordance with DIN EN ISO 9001:2000 the quality of our products is guaranteed.

Specification

- two-part, transparent shell
- PUR and hardener in tins or alternatively in double-chamber bags
- sealings
- stirring spatula (for tins)
- emery cloth
- protection gloves
- installation instructions